

# MULTI-SPOT WELDER ELECTRODE ADAPTERS

CMW electrode adapters for multispot air or hydraulic pistons are supplied with 3/4 diameter straight piston rod ends. These adapters are equipped with means for attaching the welding cable from the transformer and the water hoses to the inlet and outlet water connections.

These adapters are available in four basic assemblies as shown in the table.

## MULTI-SPOT WELDER ELECTRODE ADAPTER REPLACEMENT PARTS

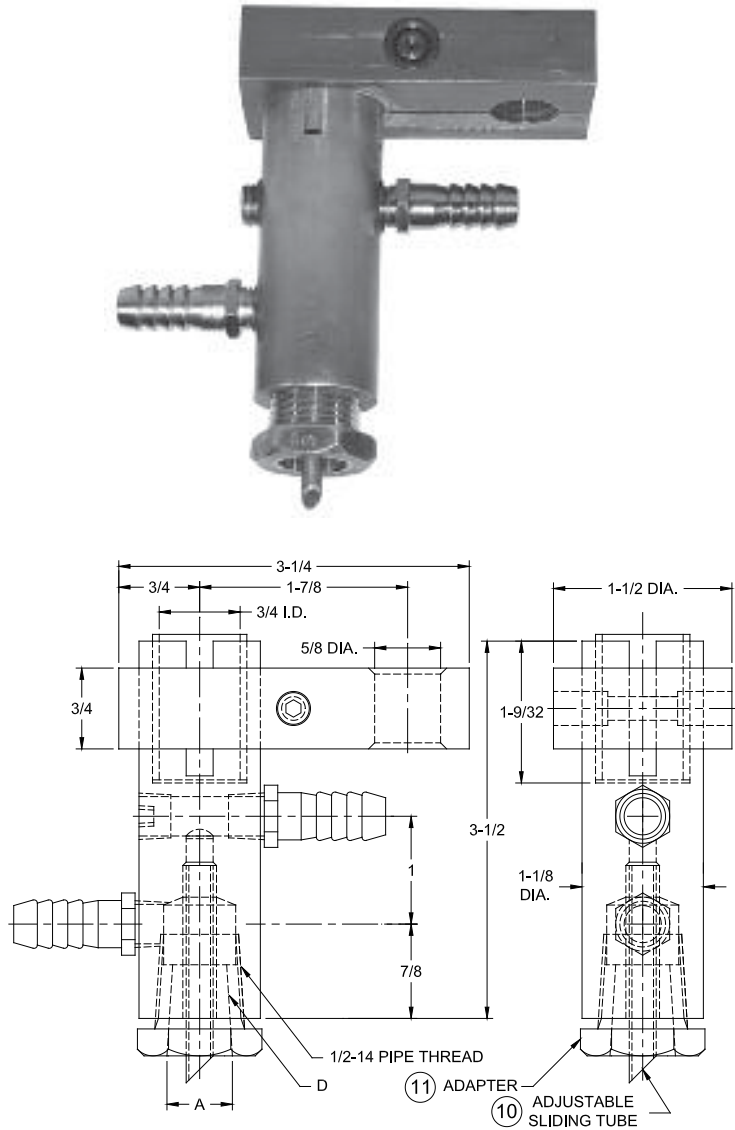
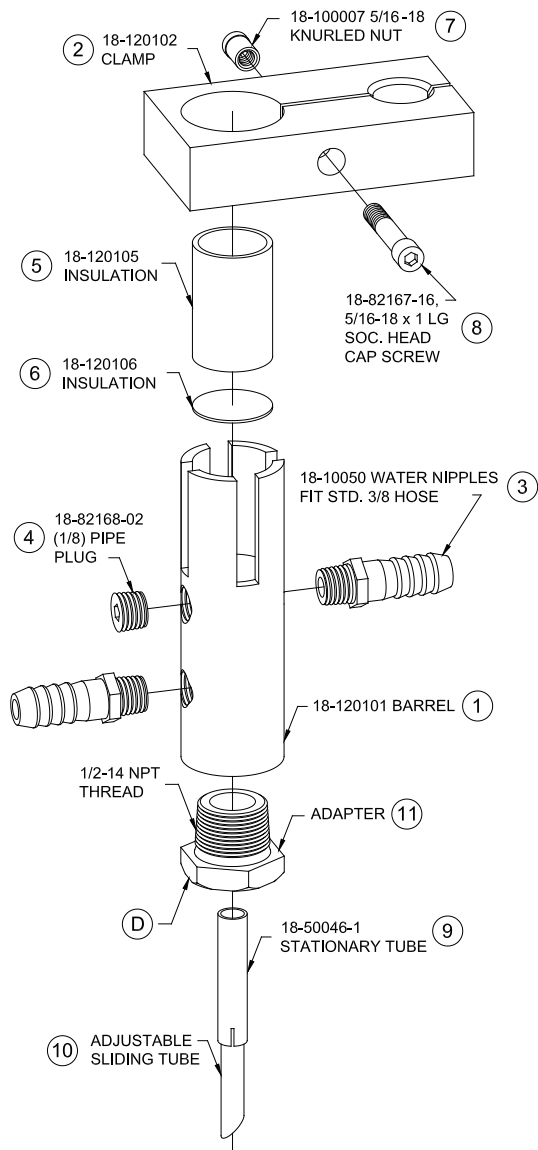

| Part No. Assembly | Major Tape Dia. A | Attachment Type D | Adjustable Sliding tube 10 | Adapter Part No. 11* |
|-------------------|-------------------|-------------------|----------------------------|----------------------|
| 18-1201           | --                | 1/2-14 NPT        | 18-10046-23                | --                   |
| 18-1202           | .414              | 5 RW Male cap     | --                         | 18-7465-07           |
| 18-1203           | .463              | 4 RW              | 18-10046-23                | 18-746-07            |
| 18-1204           | .625              | 5 RW              | 18-10046-23                | 18-747-07            |

All assemblies include items 1, 2, 3, 4, 5, 6, 7, 8, and 9.

\* See page 31 for adapter details.